

**CROSSPRO**  
PROTECTION PARTS

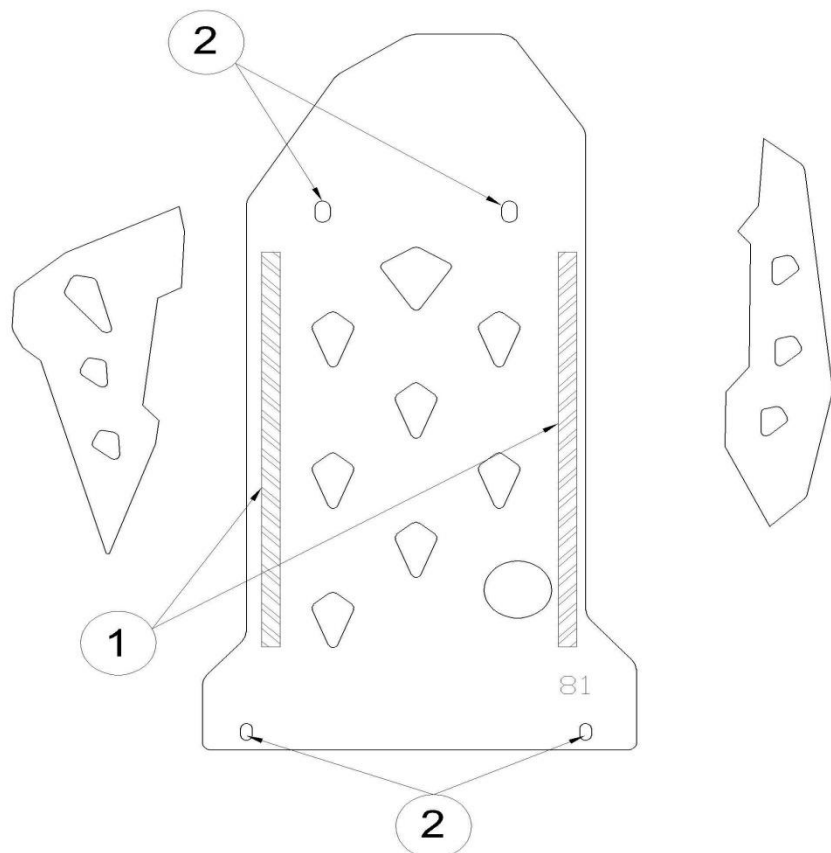

**AL. Engine Guard EC**  
**BMW G 450 X 2009-10**  
Ref: 2CP0590081



ID.013.01

2	-	Original Screws	-	4
1	-	Protective Strip	1 Mt	1
Item Nº	Referencia	Componente (Component)	Descrição (Description)	Quant.

**Assembly Sequence**

**English:**

- **1<sup>st</sup>** : Aluminum Engine protection part and kit of components. Apply strips on the insides of the central part of the protection in order to stay between the frame of the bike and the Aluminum protection.
- **2<sup>nd</sup>** : Mount protection on the motorcycle with Item Nº2 (Original Screws).
- **3<sup>rd</sup>** : Tight all screws.m

**AL. Engine Guard EC  
BMW G 450 X 2009-10**

**Français:**

- **1er** : Protection de Moteur en Aluminium et kit de composants. Appliquer Item Nº1 (Strip) sur l'intérieur de la partie centrale de la protection afin de rester entre le châssis de la moto et la protection en aluminium.
- **2er** : Monter la protection sur la moto avec Item Nº2 (Original Screws).
- **3er** : Serrer toutes les vis.

**Português:**

- **1º** : Protecção de motor em alumínio e kit de componentes. Aplicar as tiras no interior da parte central da protecção de forma a ficar entre a protecção de alumínio e o quadro.
- **2º** : Montar protecção na moto com o Item Nº2 (Original Screws).
- **3º** : Apertar todos os parafusos.