

Français:

Attention - Suivez la séquence d'instructions d'assemblage comme vous pouvez voir sur les photos.

Protection de radiateur et kit de composants.

- **1er Photo:** Retirez le côté plastiques de la moto.
 - **2er / 3er Photos:** Appliquer l'item N°2 (Tige d'Aluminium – x3) en la piece de protection R IN avec l'item N°1 (Vis – x3). Retirez radiateur de la moto et monter la assemblage précédent monté sur le radiateur, appliquer sur la moto avec les vis d'origine. Appliquer protection R OUT avec l'item N°1 (Vis – x3).
 - **4er Photo:** Monter côté plastique.
- Répétez lem processus sur le côté gauche.**



ALUMINUM RADIATOR GUARD

HONDA CRF 450 R 2015-2016

Ref.: 2CP0600142

CROSSPRO
PROTECTION PARTS



ALUMINUM RADIATOR GUARD

HONDA CRF 450 R 2015-2016

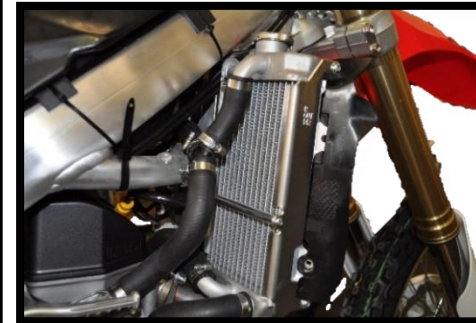
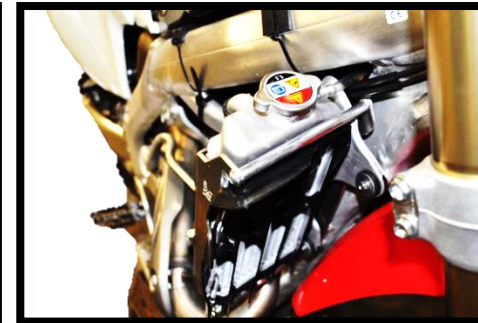
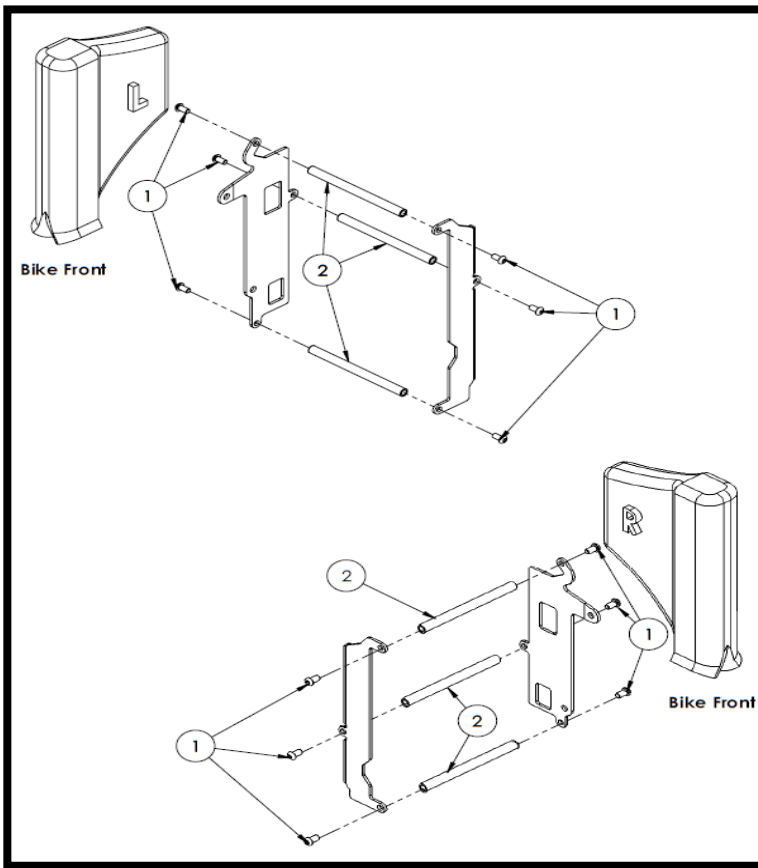

2	Haste Alumínio / Aluminum Rod	134mm	6
1	Paraf. Cabeça Redonda Sext. Int. c. FA / Screw Round Head With Washer False	M6x12 - ISO 7380	12
ITEM Nº: COMPONENTE (COMPONENT):		DESCRIÇÃO (DESCRIPTION):	QUANT.:
ACESSÓRIOS (ACCESSORIES)			

ASSEMBLY SEQUENCE / INSTRUÇÃO DE MONTAGEM

English:

Attention – Follow the assembly instruction sequence has you can see in the photos.

Aluminum radiator guard and kit of components.

- **1st Photo:** Remove side plastics.
 - **2nd / 3rd Photos:** Apply item Nº2 (Aluminum Rod – x3) in R IN protection part with item Nº1 (Screw – x3). Remove motorcycle radiator and mount set previously assembled on the radiator, apply on the motorcycle with original screws. Apply R OUT protection with item Nº1 (Screw – x3).
 - **4th Photo:** Mount side plastic.
- Repeat the process to the left side.**

Português:

Atenção – Siga a sequência de instrução de montagem que pode ver nas fotos.

Proteção radiador em alumínio e kit de componentes.

- **1º Foto:** Retirar plásticos laterais da moto.
 - **2º / 3º Fotos:** Aplicar o item Nº2 (Haste Alumínio – x3) na peça de proteção R IN com o item Nº1 (Parafuso – x3). Remover radiador da moto e montar o conjunto anteriormente montado no radiador, aplicar na moto com parafusos de origem. Aplicar proteção R OUT com o item Nº1 (Parafuso – x3).
 - **4º Foto:** Montar plásticos laterais.
- Repetir o processo para o lado esquerdo.**